

# PowerLine™ 200 Gen 2 AC LED Tape Light



PowerLine offers the highest quality ETL Listed direct-connect LED lighting, with the greatest selection of options on the market today. The Alloy LED manufacturing facility in California offers built to order, ETL listed custom lengths of PowerLine with a lightning-fast lead time.

- Custom ETL Listed Lengths
- Available with Either Plug-In (UL-2388) or Hard-Wire (UL 1598) Configurations
- Dimmable with Standard Household AC Dimmers
- Cut Points Every 12 Inches
- Up to 272 Lumens / Foot

## TECHNICAL INFORMATION

<b>Stocked Color Temperature*</b>	2700K, 3000K, 3500K, 4200K
<b>Power Consumption per foot</b>	3 Watts / 28mA
<b>Input Voltage</b>	120V AC
<b>Lumens Per Foot</b>	256 (avg.)
<b>Spool Length</b>	164 ft.
<b>Tape Dimensions (W x H)</b>	0.6 x 0.264 in.
<b>End Cap Dimensions (L x W x H)</b>	0.69 x 0.69 x 0.44 in.
<b>Maximum Run Length</b>	164 ft.
<b>Dimmable</b>	Yes (Down to 25%)
<b>Beam Angle</b>	105.75°

<b>Cut Points</b>	Every 12 in.
<b>Power Cable Length</b>	2 ft. / 8 ft.
<b>Diode Type</b>	2835
<b>Diodes per foot</b>	36
<b>Diode Spacing</b>	0.34 in.
<b>Location</b>	Dry / Wet (IP65)
<b>Operating Temperature</b>	-4° F to 107° F / -20° C to 42° C
<b>Ambient Temperature</b>	32° F to 107° F / 0° C to 42° C
<b>Certifications / Standards</b>	ETL Listed, UL 2388 (plug-in), UL 1598 (hard-wire), RoHS
<b>Warranty</b>	5 Years Indoor, 3 Years Outdoor

\* In addition to stocked colors, a wide variety of Color Temperatures are also available by special order. Please call or email to order.

## ETL LISTED CUSTOM LENGTHS

Use the SKU builder to fill in the CCT (Color Temperature) and length (in feet).

### Plug-in SKU Builder:

AL - 11 - 36 - A - [CCT] - [LENGTH]  
 (Choice of Color Temperature) (Choice of length 1 ft. increments)  
 27 = 2700K  
 30 = 3000K  
 35 = 3500K  
 42 = 4200K

### Hard-wire SKU Builder:

AL - 11 - 36 - B - [CCT] - [LENGTH]

### Examples:

- AL - 11 - 36 - A - 30 - 039  
Plug-in PowerLine 200 Gen 2 AC Tape - 3000K - 39 feet
- AL - 11 - 36 - B - 35 - 108  
Hard-wire PowerLine 200 Gen 2 AC Tape - 3500K - 108 feet



## ALLOY LED LIGHT LAB™ SPECIFICATIONS

Maximum Run = 164'

Item Number	Voltage	Color Temperature*	CRI	R9 Value	R13 Value	TM-30	CQS	Lumens per foot
AL-11-36-A-27-XXX	120V AC	2700K	94.5	84	96	95.2	93.9	238.0
AL-11-36-A-30-XXX	120V AC	3000K	95.5	89	95	95.7	95.8	252.8
AL-11-36-A-35-XXX	120V AC	3500K	95.7	88	96	95.7	97.6	263.4
AL-11-36-A-42-XXX	120V AC	4200K	95.5	74	96	93.1	95.9	272.2

## TAPE LIGHT DIMENSION DIAGRAMS

LED Strip with Power Connector and End Cap

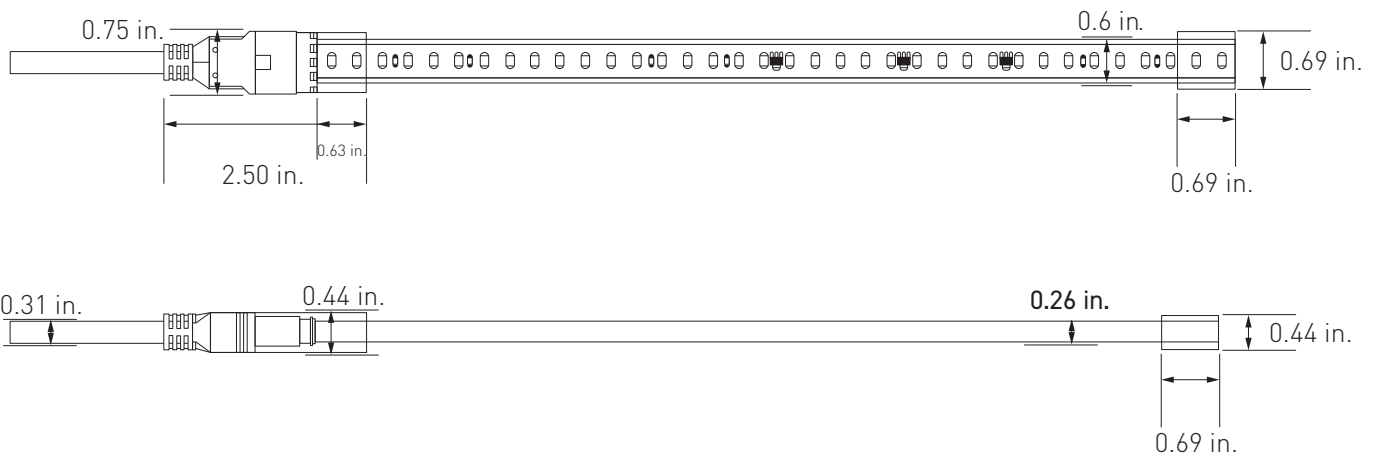

Plug-In Configuration (UL 2388)

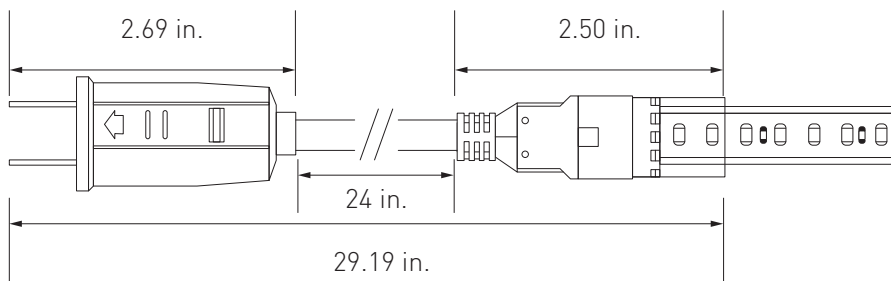

Hard-Wire Configuration (UL 1598)

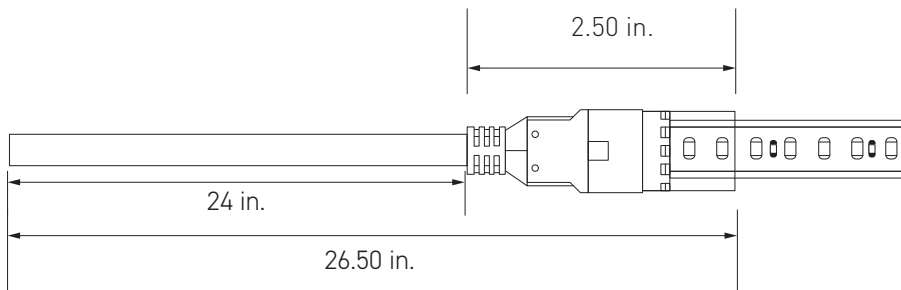

## ACCESSORIES (SOLD SEPARATELY)

### Mounting Accessories

PowerLine Tape Light End Caps do not fit in any of the mounting tracks or channel kits.

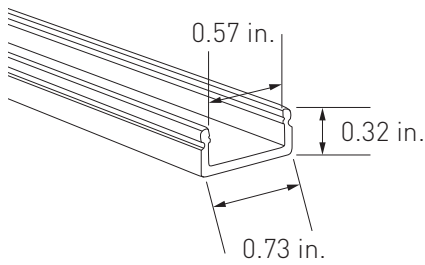

**Universal Aluminum Mounting Track  
(Screws not included)**

AL-11-99-9923-AL (4 ft. - Aluminum)

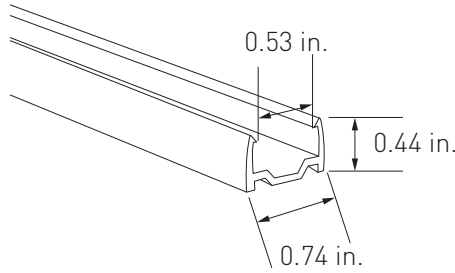

**Universal Plastic Mounting Track  
(Screws not included)**

AL-11-99-9930 (4 ft. - Plastic)

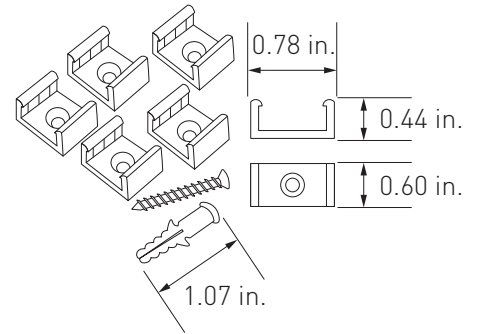

**Universal Plastic Mounting Clips/Screws  
(Attach directly to PowerLine)  
White - Pack of 5**

AL-11-99-9902-MC (5-pack)  
Includes 5 screws (1 in.) and anchors

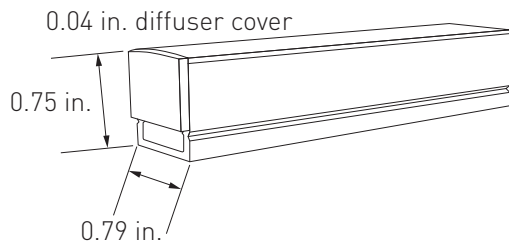

**Universal Surface-Mount Channel Kit - 4ft.  
1 Aluminum Channel, 1 Premium Diffuser Cover 1mm  
height, 2 End Caps, 4 Metal Mounting Clips/Screws**

AL-11-99-9924-KIT

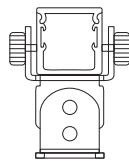
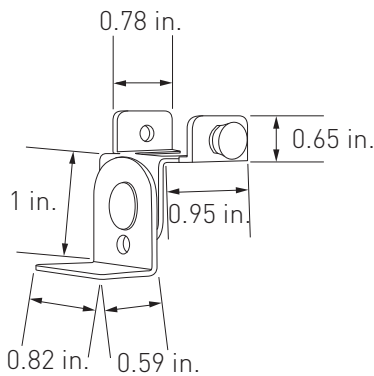

0°

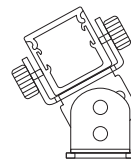

30°

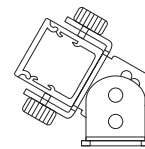

60°

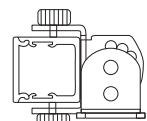

90°

**Universal Adjustable Channel Mounting Bracket/Screws  
Compatible with Surface Mount Channel**

AL-11-99-9986  
Use 2 every 4 ft.

NOTE: The tape light end cap does not fit in the track.

## ACCESSORIES (SOLD SEPARATELY)

### Additional Accessories

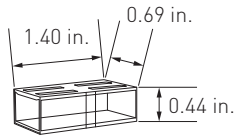

**Universal Clear Tape-to-Tape Connector**  
AL-11-99-9902-DC

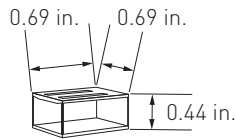

**Universal End Cap**  
AL-11-99-9902-EC (Clear)

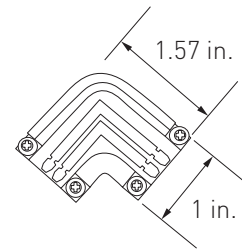

**Universal L-Connector with Screws - 90 Degree**  
AL-11-99-9902-LC

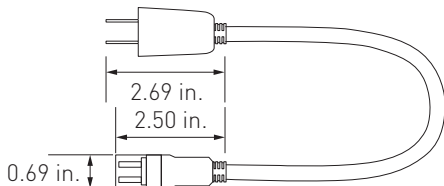

**Plug-In Universal Power Cable\***  
AL-11-99-9902-USD-24IN (24 in. - White)  
AL-11-99-9902-USD-96IN (96 in. - White)

*\*When measuring your job, please add 5.19 in. to your chosen length (24 in. or 96 in.) to account for the plugs.*

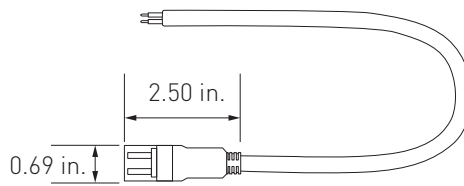

**Hard-Wire Universal Power Feed Splice Connector\***  
AL-11-99-9902-SC-24IN (24 in. - White)  
AL-11-99-9902-SC-96IN (96 in. - White)

*\*When measuring your job, please add 2.50 in. to your chosen length (24 in. or 96 in.) to account for the plugs.*

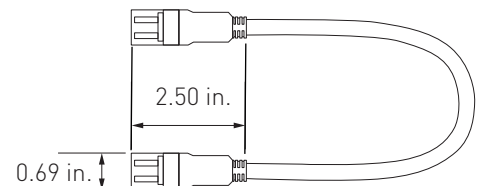

**Universal Jumper Cable\***  
AL-11-99-9902-EXT-6IN (6 in. - White)  
AL-11-99-9902-EXT-24IN (24 in. - White)

*\*When measuring your job, please add 5 in. to your chosen length (6 in. or 24 in.) to account for the plugs.*

## DIMMER COMPATIBILITY

---

PowerLine 200 Gen 2 is dimmable when used with standard household AC dimmers.

### Alloy LED Light Lab Tested Dimmers for PowerLine 200 Gen 2 Tape

Brand	Model	Model Number	Input
LUTRON	SKYLARK	CTCL-153P	100-130V
	MAESTRO	MACL-153M	100-130V
	MAESTRO	MACL-153MR	100-130V
LEGRAND	ADORNE SOFTAP	ADTP700RMTUW1	100-130V
LEVITON	DECORA	6161-A	100-130V
	SURESLIDE	6633	100-130V
	SURESLIDE	6633-PLW	100-130V
	SURESLIDE	6633-POG	100-130V
	DECORA SURESLIDE	6674	100-130V
INSTEON	6 BUTTON KEYPAD	2334-232	100-130V
	SWITCHLINC	2477D	100-130V
	LAMPINC	2457D2	100-130V
GE	Z-WAVE	12724	100-130V
	Z-WAVE	45602	100-130V
	PUSH ON/OFF	52136	100-130V

Note: specifications are representative of the diode type and not a particular tape light article.

2700K

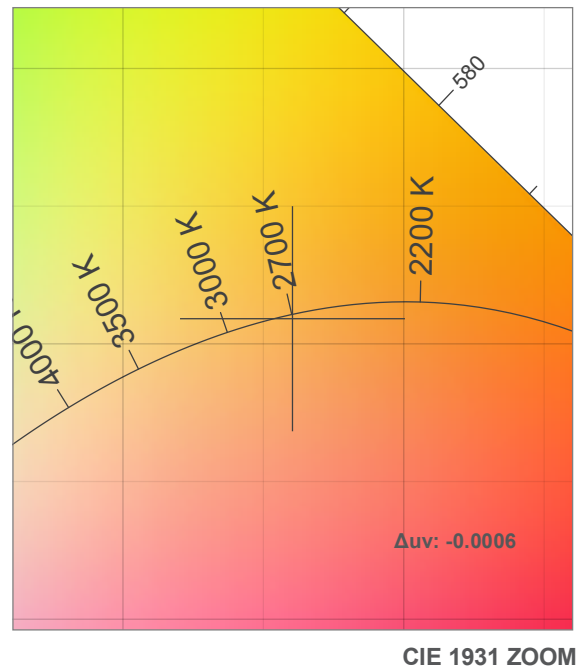
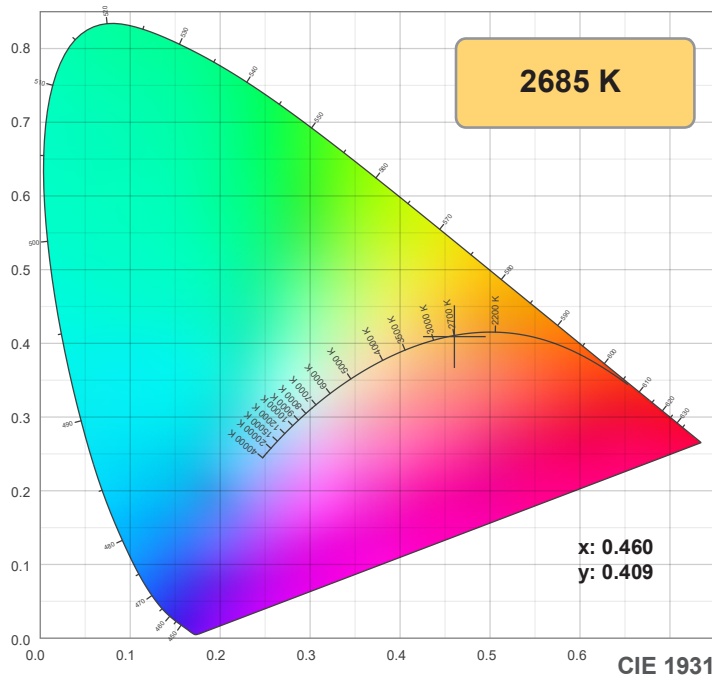

TM-30: 95.2

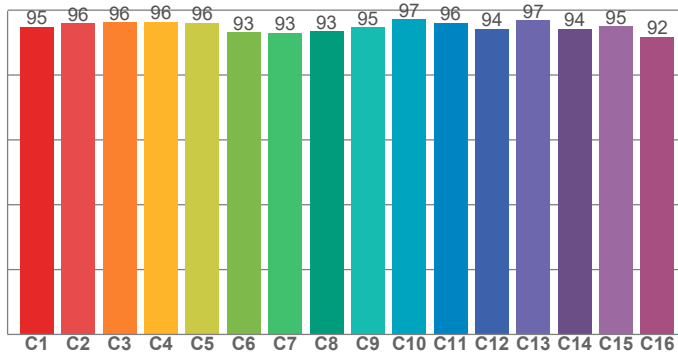

CRI: 94.5 (R1-R8)

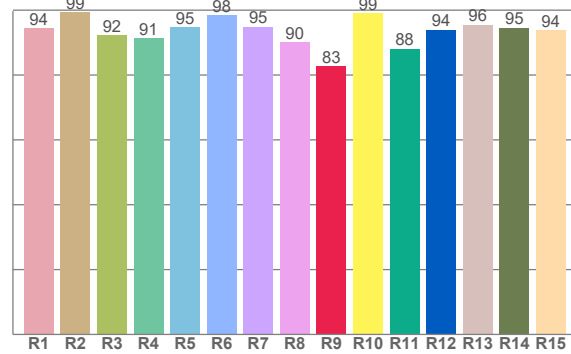

CRI R values, only R1-R8 are used to calculate final CRI value

R1	R2	R3	R4	R5	R6	R7	R8	R9	R10	R11	R12	R13	R14	R15
94.4	99.3	92.3	91.3	94.9	98.4	94.9	90.1	82.6	99.2	88.2	94.0	95.5	94.6	93.7

TM30 C values, 16 binned values out of total of 99 C values

C1	C2	C3	C4	C5	C6	C7	C8	C9	C10	C11	C12	C13	C14	C15	C16
94.8	95.9	96.3	96.5	96.1	93.2	93.0	93.4	94.7	97.1	96.1	94.3	96.9	94.2	95.1	91.8

CQS Q values

Q1	Q2	Q3	Q4	Q5	Q6	Q7	Q8	Q9	Q10	Q11	Q12	Q13	Q14	Q15
96.6	97.1	93.5	96.6	92.0	88.7	92.1	97.1	95.0	96.5	96.0	94.2	93.8	95.9	96.4

CQS: 93.9

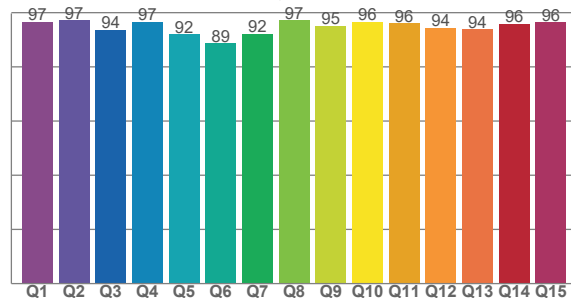

Color parameters

Color temperature	Color rendering index	Red component	Color fidelity	Color gamut	Color quality scale	Color coordinate cie 1931	Color coordinate cie 1931	Color coordinate	Color coordinate	Color deviation from black body
CCT	CRI	CRI R9	TM30 Rf	TM30 Rg	CQS	x	y	u	v	Δuv
2685 K	94.5	82.6	95.2	104.8	93.9	0.460	0.409	0.263	0.351	-0.0006

Note: specifications are representative of the diode type and not a particular tape light article.

2700K

**Rf 95.2**  
Fidelity index Rf

**Rg 104.8**  
Gamut index Rg

Hue Bin	R <sub>f</sub>	Shifts (%)	
		Chroma	Hue
1	95	2%	-1%
2	96	2%	-2%
3	96	1%	0%
4	96	0%	0%
5	96	2%	2%
6	93	5%	2%
7	93	4%	0%
8	93	3%	-3%
9	95	2%	-3%
10	97	0%	-1%
11	96	1%	2%
12	94	3%	2%
13	97	2%	1%
14	94	4%	1%
15	95	2%	0%
16	92	5%	-4%

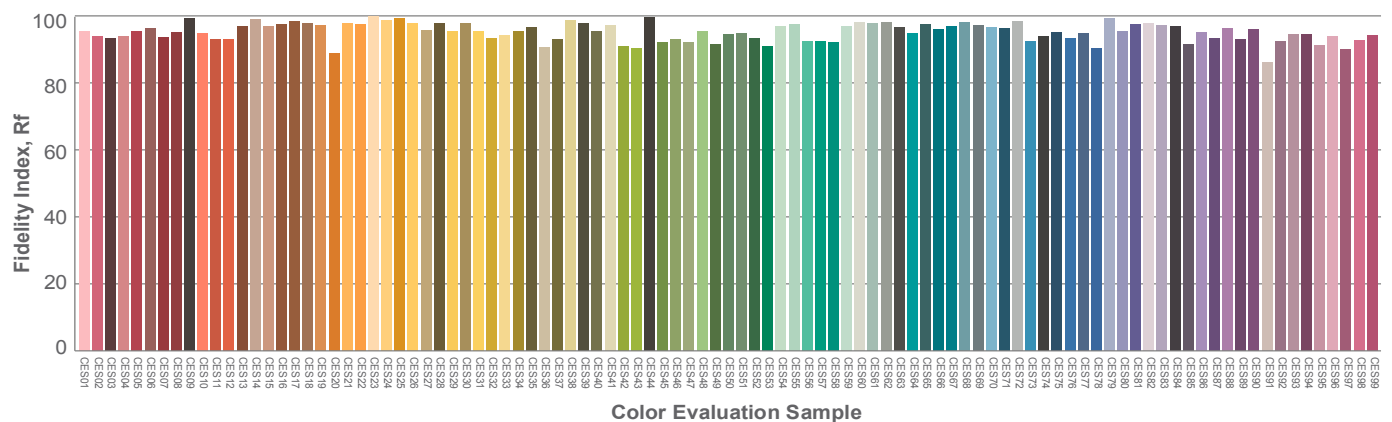
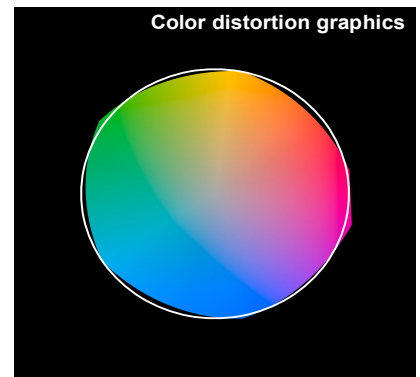
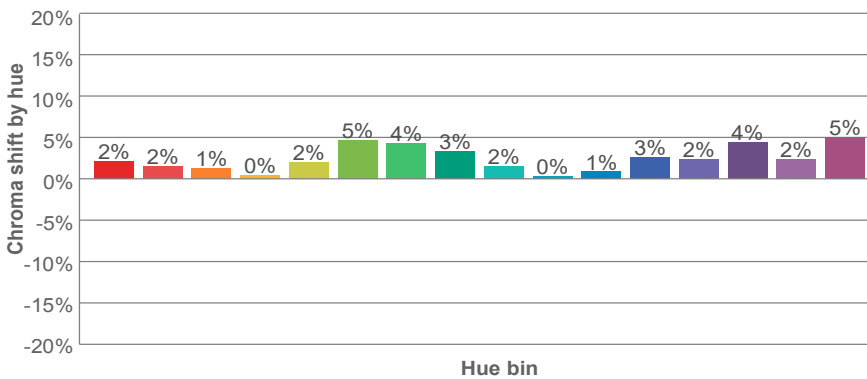
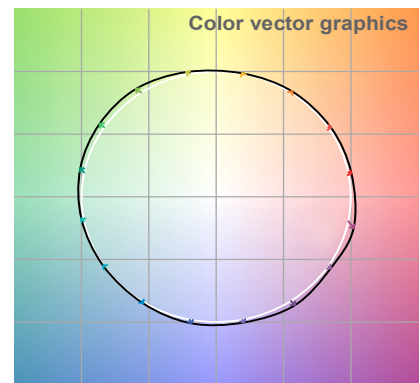
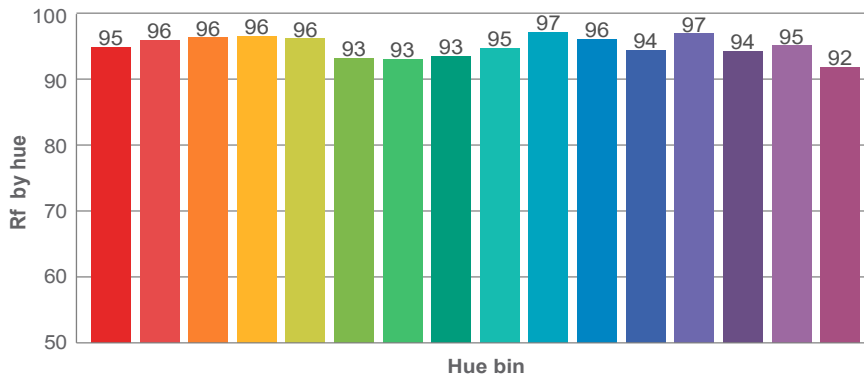
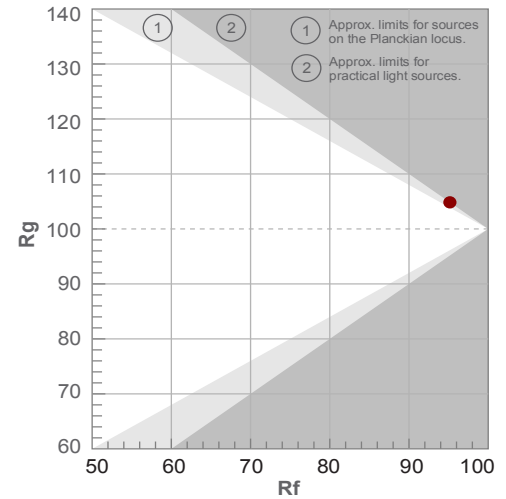

Note: specifications are representative of the diode type and not a particular tape light article.

2700K

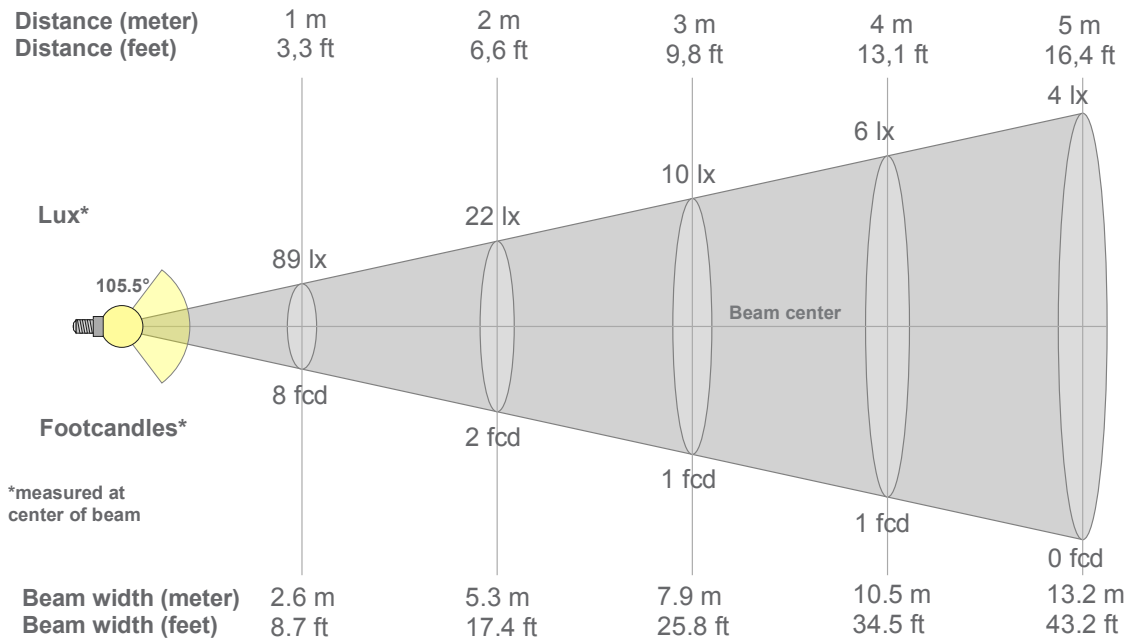

**Beam intensities from 1-20m**

1m	2m	3m	4m	5m	6m	7m	8m	9m	10m	11m	12m	13m	14m	15m	16m	17m	18m	19m	20m
3.3ft	6.6ft	9.8ft	13.1ft	16.4ft	19.7ft	23ft	26.2ft	29.5ft	32.8ft	36.1ft	39.4ft	42.7ft	45.9ft	49.2ft	52.5ft	55.8ft	59.1ft	62.3ft	65.6ft
89lx	22lx	10lx	6lx	4lx	2lx	2lx	1lx	1lx	1lx	1lx	1lx	1lx	0lx	0lx	0lx	0lx	0lx	0lx	0lx
8.2fcd	2.1fcd	0.9fcd	0.5fcd	0.3fcd	0.2fcd	0.2fcd	0.1fcd	0.1fcd	0.1fcd	0.1fcd	0.1fcd	0fcd	0fcd	0fcd	0fcd	0fcd	0fcd	0fcd	0fcd

**Intensities in 0° c-plane**

0°	5°	10°	15°	20°	25°	30°	35°	40°	45°	50°	55°	60°	65°	70°	75°	80°	85°	90°	95°
88.6	88.4	87.0	84.8	81.9	78.2	73.7	68.7	62.8	56.2	48.7	40.8	33.2	25.8	18.6	12.4	7.8	4.4	2.2	0.9
100%	100%	98%	96%	92%	88%	83%	77%	71%	63%	55%	46%	37%	29%	21%	14%	9%	5%	2%	1%

**Intensities in 90° c-plane**

0°	5°	10°	15°	20°	25°	30°	35°	40°	45°	50°	55°	60°	65°	70°	75°	80°	85°	90°	95°
88.6	88.4	87.0	84.8	81.9	78.2	73.7	68.7	62.8	56.2	48.7	40.8	33.2	25.8	18.6	12.4	7.8	4.4	2.2	0.9
100%	100%	98%	96%	92%	88%	83%	77%	71%	63%	55%	46%	37%	29%	21%	14%	9%	5%	2%	1%

**Intensities in 180° c-plane**

0°	5°	10°	15°	20°	25°	30°	35°	40°	45°	50°	55°	60°	65°	70°	75°	80°	85°	90°	95°
88.6	88.4	87.0	84.8	81.9	78.2	73.7	68.7	62.8	56.2	48.7	40.8	33.2	25.8	18.6	12.4	7.8	4.4	2.2	0.9
100%	100%	98%	96%	92%	88%	83%	77%	71%	63%	55%	46%	37%	29%	21%	14%	9%	5%	2%	1%

**Intensities in 270° c-plane**

0°	5°	10°	15°	20°	25°	30°	35°	40°	45°	50°	55°	60°	65°	70°	75°	80°	85°	90°	95°
88.6	88.4	87.0	84.8	81.9	78.2	73.7	68.7	62.8	56.2	48.7	40.8	33.2	25.8	18.6	12.4	7.8	4.4	2.2	0.9
100%	100%	98%	96%	92%	88%	83%	77%	71%	63%	55%	46%	37%	29%	21%	14%	9%	5%	2%	1%

Beam angle 50%	Field angle 10%	Cutoff angle 2,5%	Intensity ratio in 120° cone	Intensity ratio in 90° cone
105.5°	157.6°	179.8°	80.2%	55.9%



Note: specifications are representative of the diode type and not a particular tape light article.

3000K

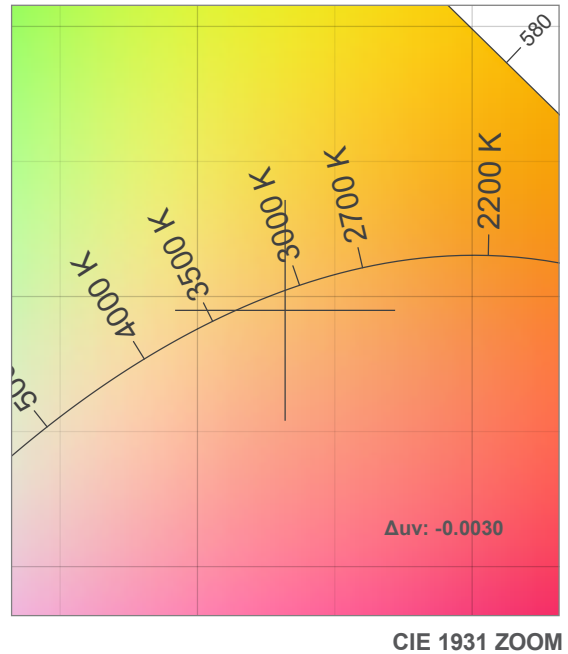
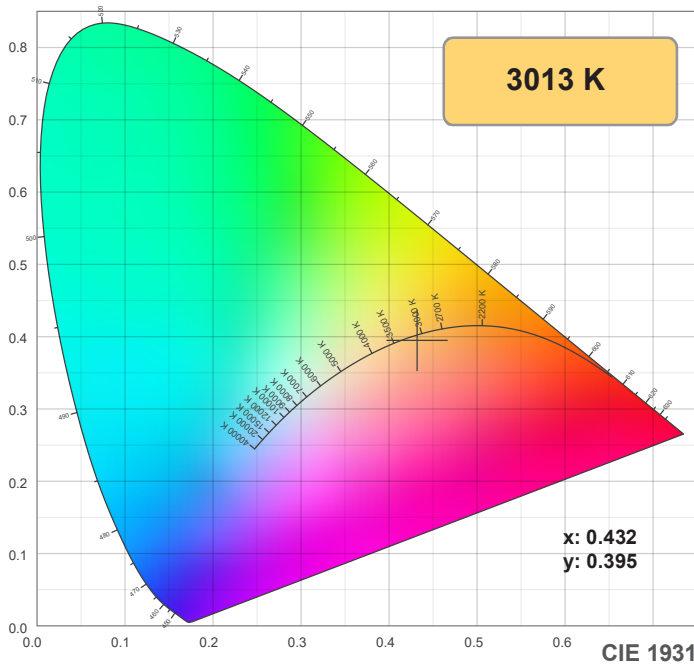

TM-30: 95.7

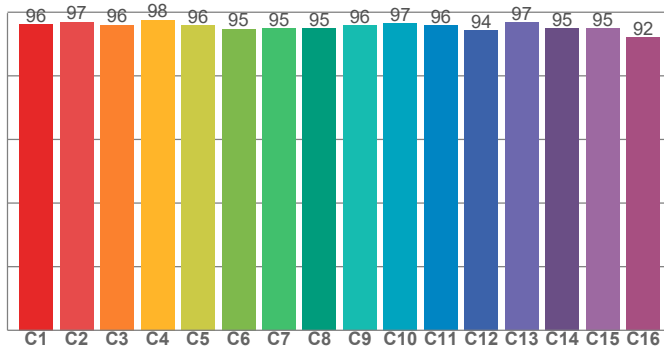

CRI: 95.5 (R1-R8)

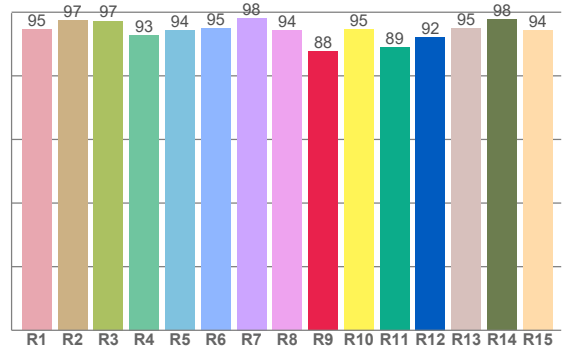

CRI R values, only R1-R8 are used to calculate final CRI value

R1	R2	R3	R4	R5	R6	R7	R8	R9	R10	R11	R12	R13	R14	R15
94.5	97.4	97.3	92.9	94.2	95.1	98.1	94.3	87.6	94.8	88.9	92.3	94.9	97.7	94.4

TM30 C values, 16 binned values out of total of 99 C values

C1	C2	C3	C4	C5	C6	C7	C8	C9	C10	C11	C12	C13	C14	C15	C16
96.2	96.9	96.0	97.6	96.0	94.7	94.8	94.9	95.8	96.6	95.8	94.4	96.8	95.0	95.0	92.0

CQS Q values

Q1	Q2	Q3	Q4	Q5	Q6	Q7	Q8	Q9	Q10	Q11	Q12	Q13	Q14	Q15
97.6	98.1	94.9	97.7	94.1	91.8	94.6	98.2	97.6	98.0	97.4	97.0	97.3	96.2	96.9

CQS: 95.8

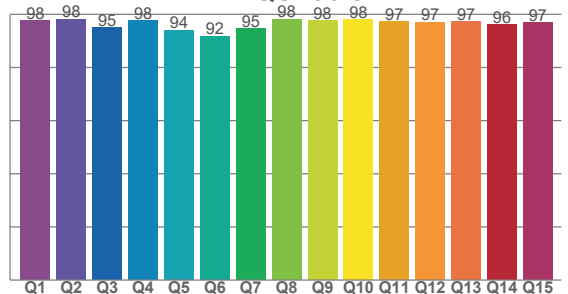

Color parameters

Color temperature	Color rendering index	Red component	Color fidelity	Color gamut	Color quality scale	Color coordinate cie 1931	Color coordinate cie 1931	Color coordinate	Color coordinate	Color deviation from black body
CCT	CRI	CRI R9	TM30 Rf	TM30 Rg	CQS	x	y	u	v	Δuv
3013 K	95.5	87.6	95.7	104.2	95.8	0.432	0.395	0.251	0.345	-0.0030

Note: specifications are representative of the diode type and not a particular tape light article.

3000K

**Rf 95.7**  
Fidelity index Rf

**Rg 104.2**  
Gamut index Rg

Hue Bin	R <sub>f</sub>	Shifts (%)	
		Chroma	Hue
1	96	1%	-1%
2	97	1%	-1%
3	96	1%	0%
4	98	1%	0%
5	96	0%	1%
6	95	3%	1%
7	95	3%	0%
8	95	3%	-1%
9	96	2%	-1%
10	97	1%	0%
11	96	2%	1%
12	94	3%	0%
13	97	2%	-1%
14	95	4%	-1%
15	95	2%	-1%
16	92	4%	-5%

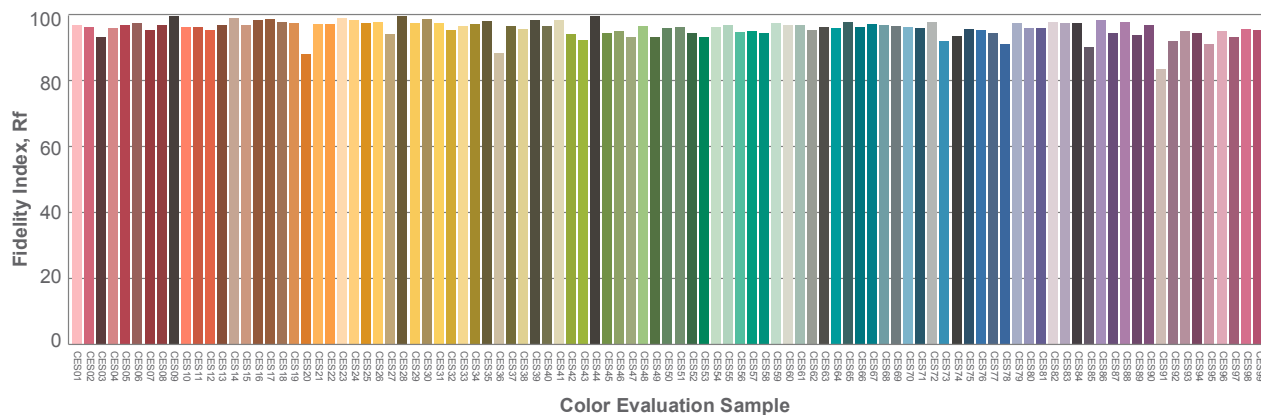
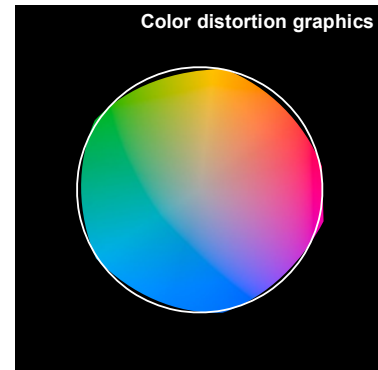
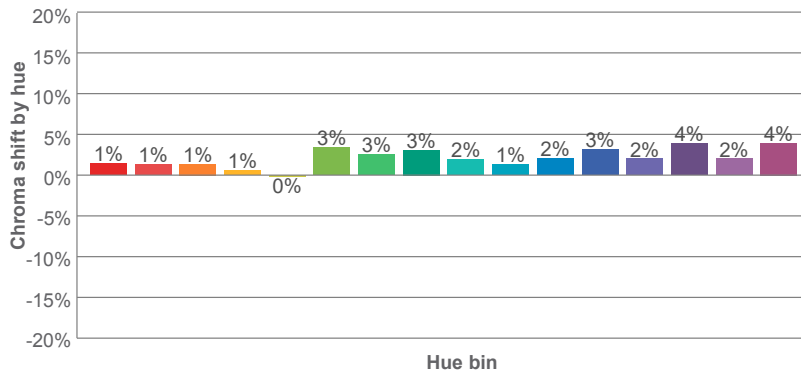
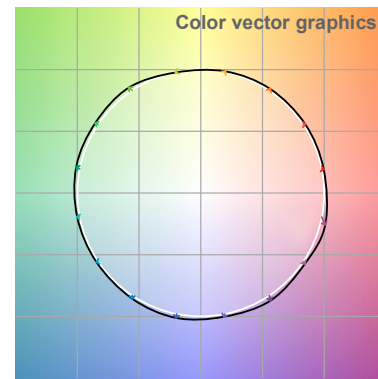
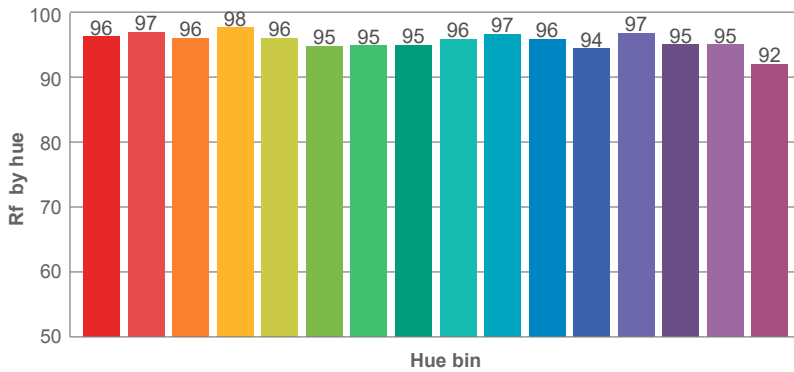
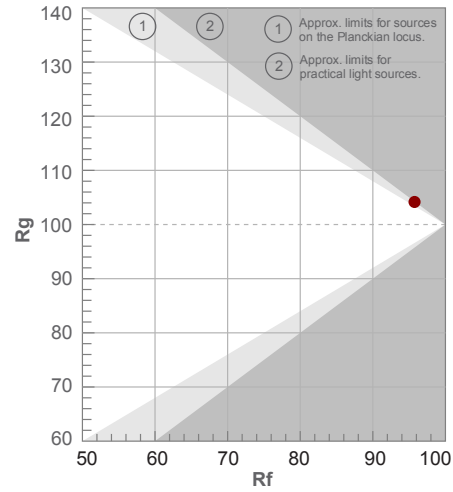

Note: specifications are representative of the diode type and not a particular tape light article.

3000K

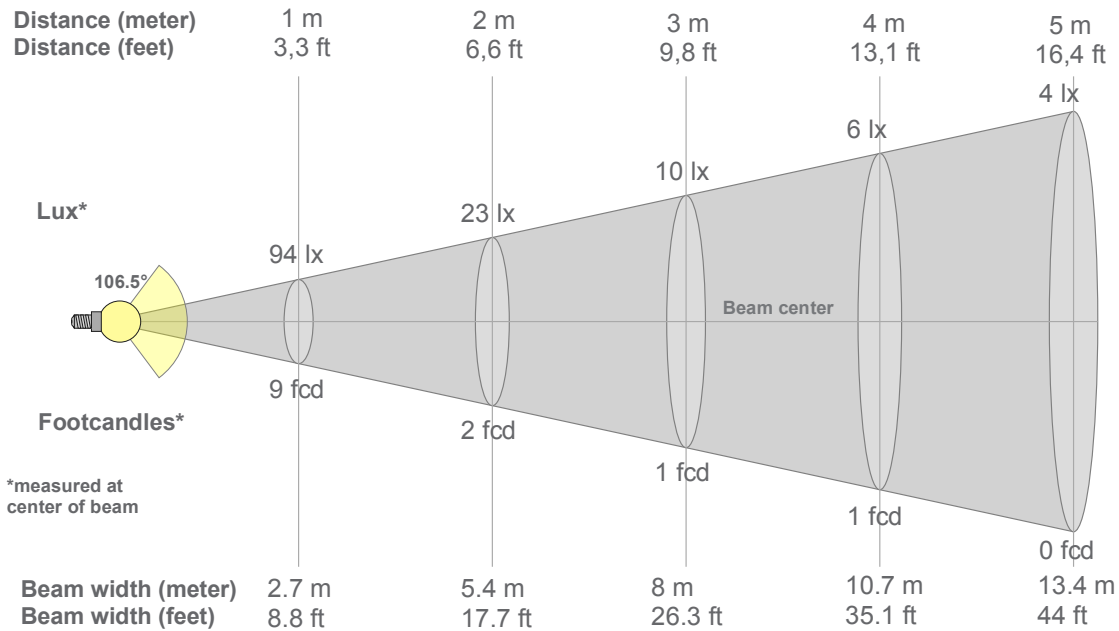

**Beam intensities from 1-20m**

1m	2m	3m	4m	5m	6m	7m	8m	9m	10m	11m	12m	13m	14m	15m	16m	17m	18m	19m	20m
3.3ft	6.6ft	9.8ft	13.1ft	16.4ft	19.7ft	23ft	26.2ft	29.5ft	32.8ft	36.1ft	39.4ft	42.7ft	45.9ft	49.2ft	52.5ft	55.8ft	59.1ft	62.3ft	65.6ft
94lx	23lx	10lx	6lx	4lx	3lx	2lx	1lx	1lx	1lx	1lx	1lx	1lx	0lx	0lx	0lx	0lx	0lx	0lx	0lx
8.7fcd	2.2fcd	1fcd	0.5fcd	0.3fcd	0.2fcd	0.2fcd	0.1fcd	0.1fcd	0.1fcd	0.1fcd	0.1fcd	0.1fcd	0fcd	0fcd	0fcd	0fcd	0fcd	0fcd	0fcd

**Intensities in 0° c-plane**

0°	5°	10°	15°	20°	25°	30°	35°	40°	45°	50°	55°	60°	65°	70°	75°	80°	85°	90°	95°
93.5	93.5	92.1	89.9	86.8	82.9	78.3	73.0	67.0	60.1	52.3	43.9	35.6	27.6	19.9	13.2	8.0	4.4	2.0	0.8
100%	100%	98%	96%	93%	89%	84%	78%	72%	64%	56%	47%	38%	29%	21%	14%	9%	5%	2%	1%

**Intensities in 90° c-plane**

0°	5°	10°	15°	20°	25°	30°	35°	40°	45°	50°	55°	60°	65°	70°	75°	80°	85°	90°	95°
93.5	93.5	92.1	89.9	86.8	82.9	78.3	73.0	67.0	60.1	52.3	43.9	35.6	27.6	19.9	13.2	8.0	4.4	2.0	0.8
100%	100%	98%	96%	93%	89%	84%	78%	72%	64%	56%	47%	38%	29%	21%	14%	9%	5%	2%	1%

**Intensities in 180° c-plane**

0°	5°	10°	15°	20°	25°	30°	35°	40°	45°	50°	55°	60°	65°	70°	75°	80°	85°	90°	95°
93.5	93.5	92.1	89.9	86.8	82.9	78.3	73.0	67.0	60.1	52.3	43.9	35.6	27.6	19.9	13.2	8.0	4.4	2.0	0.8
100%	100%	98%	96%	93%	89%	84%	78%	72%	64%	56%	47%	38%	29%	21%	14%	9%	5%	2%	1%

**Intensities in 270° c-plane**

0°	5°	10°	15°	20°	25°	30°	35°	40°	45°	50°	55°	60°	65°	70°	75°	80°	85°	90°	95°
93.5	93.5	92.1	89.9	86.8	82.9	78.3	73.0	67.0	60.1	52.3	43.9	35.6	27.6	19.9	13.2	8.0	4.4	2.0	0.8
100%	100%	98%	96%	93%	89%	84%	78%	72%	64%	56%	47%	38%	29%	21%	14%	9%	5%	2%	1%

<b>Beam angle 50%</b>	<b>Field angle 10%</b>	<b>Cutoff angle 2,5%</b>	<b>Intensity ratio in 120° cone</b>	<b>Intensity ratio in 90° cone</b>
<b>106.5°</b>	<b>157.3°</b>	<b>178.4°</b>	<b>80.5%</b>	<b>56.0%</b>

Note: specifications are representative of the diode type and not a particular tape light article.

3500K

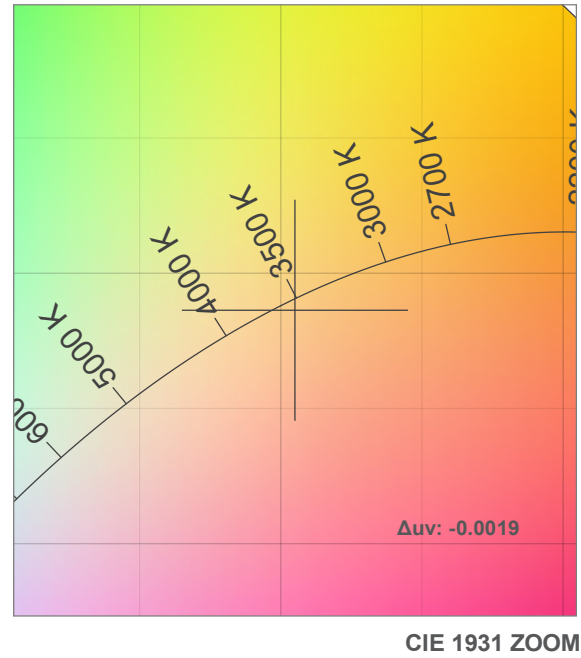
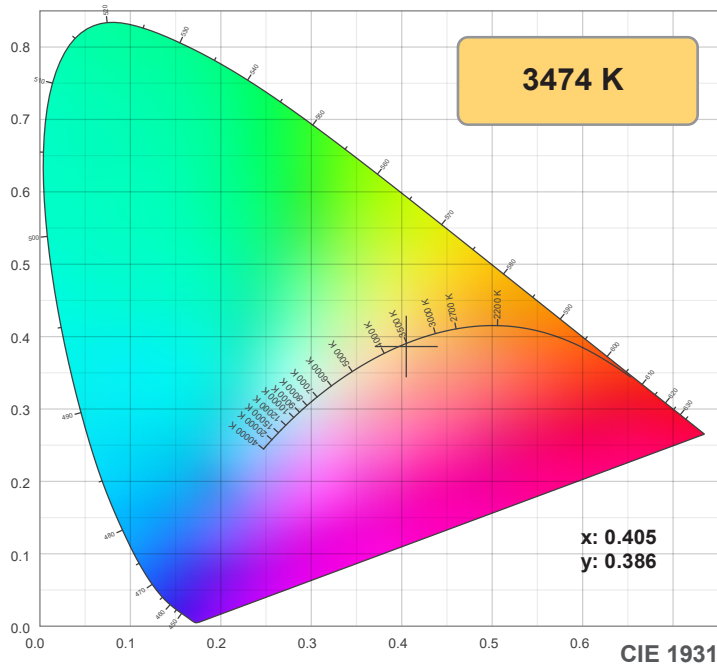

TM-30: 95.7

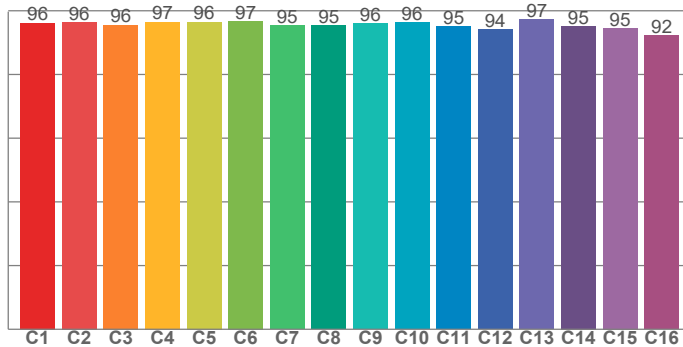

CRI: 95.7 (R1-R8)

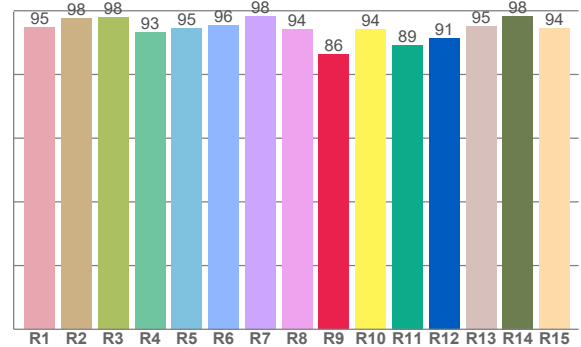

CRI R values, only R1-R8 are used to calculate final CRI value

R1	R2	R3	R4	R5	R6	R7	R8	R9	R10	R11	R12	R13	R14	R15
94.7	97.5	98.1	93.3	94.5	95.5	98.3	94.1	86.3	94.3	89.3	91.4	95.2	98.4	94.5

TM30 C values, 16 binned values out of total of 99 C values

C1	C2	C3	C4	C5	C6	C7	C8	C9	C10	C11	C12	C13	C14	C15	C16
96.2	96.4	95.6	96.6	96.5	96.7	95.3	95.4	96.0	96.3	95.0	94.1	97.2	95.2	94.6	92.2

CQS Q values

Q1	Q2	Q3	Q4	Q5	Q6	Q7	Q8	Q9	Q10	Q11	Q12	Q13	Q14	Q15
97.7	99.6	97.2	96.7	96.0	95.3	99.1	98.3	99.2	98.7	97.2	97.1	97.8	98.1	97.6

CQS: 97.6

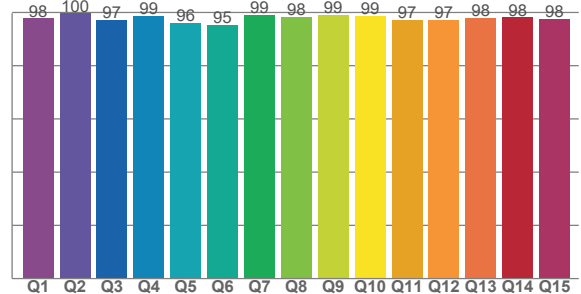

Color parameters

Color temperature	Color rendering index	Red component	Color fidelity	Color gamut	Color quality scale	Color coordinate cie 1931	Color coordinate cie 1931	Color coordinate	Color coordinate	Color deviation from black body
CCT	CRI	CRI R9	TM30 Rf	TM30 Rg	CQS	x	y	u	v	Δuv
3474 K	95.7	86.3	95.7	103.0	97.6	0.405	0.386	0.237	0.340	-0.0019

Note: specifications are representative of the diode type and not a particular tape light article.

3500K

**Rf 95.7**  
Fidelity index Rf

**Rg 103.0**  
Gamut index Rg

Hue Bin	R <sub>f</sub>	Shifts (%)	
		Chroma	Hue
1	96	2%	-1%
2	96	1%	-1%
3	96	1%	-1%
4	97	-1%	-2%
5	96	-2%	0%
6	97	2%	1%
7	95	1%	2%
8	95	2%	1%
9	96	2%	1%
10	96	2%	0%
11	95	3%	2%
12	94	3%	0%
13	97	1%	-2%
14	95	4%	-2%
15	95	2%	-1%
16	92	3%	-3%

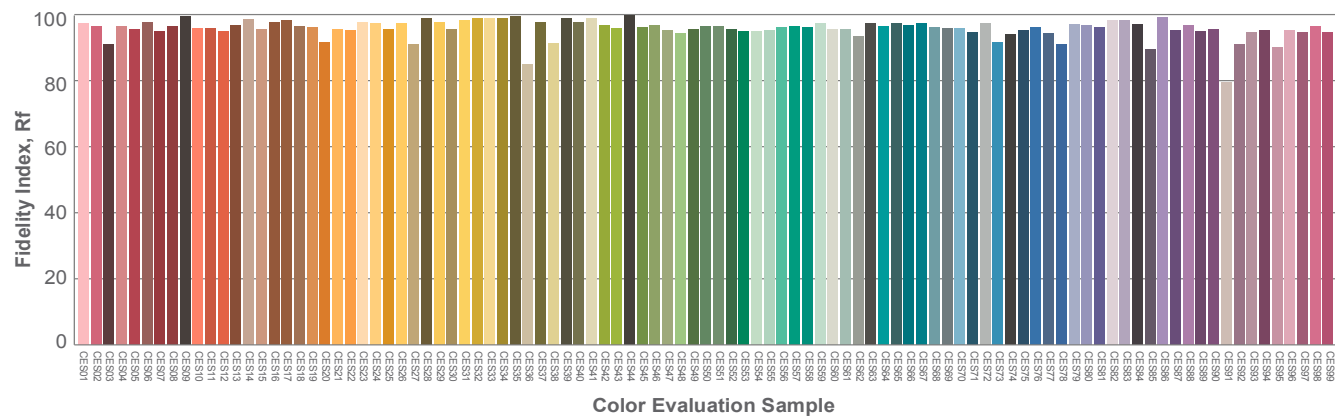
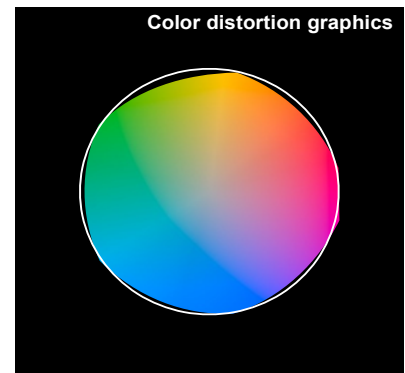
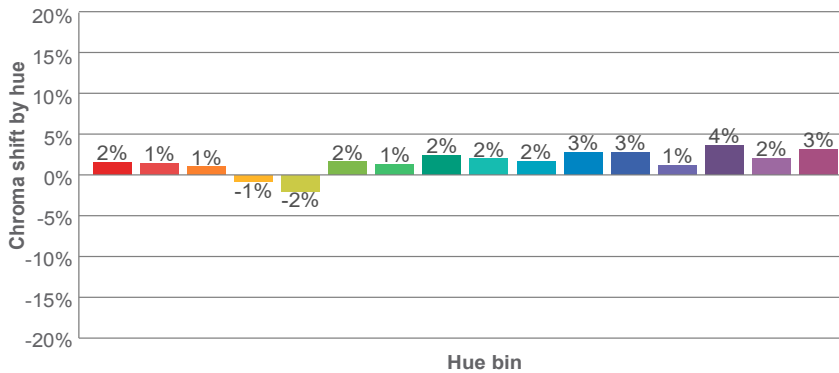
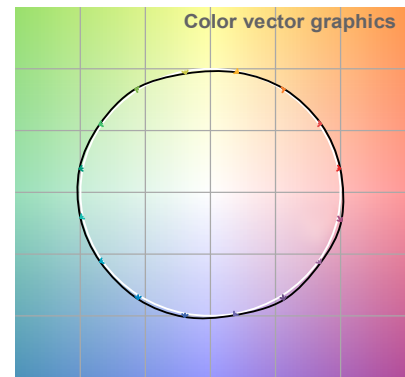
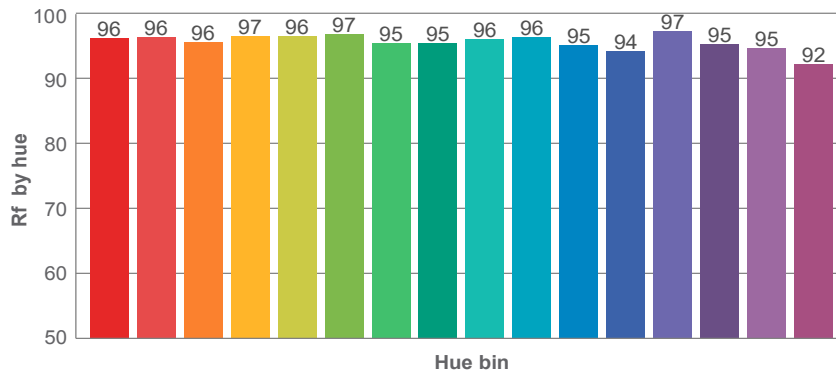
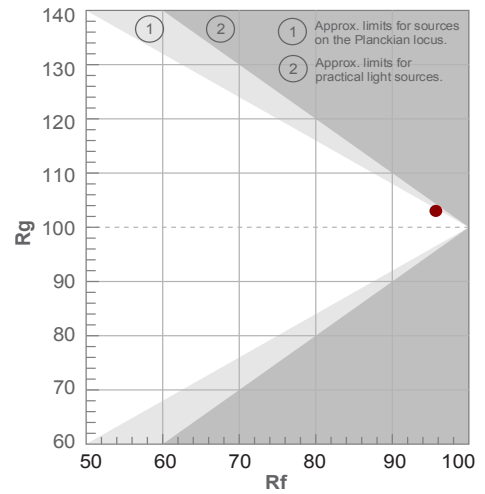

Note: specifications are representative of the diode type and not a particular tape light article.

3500K

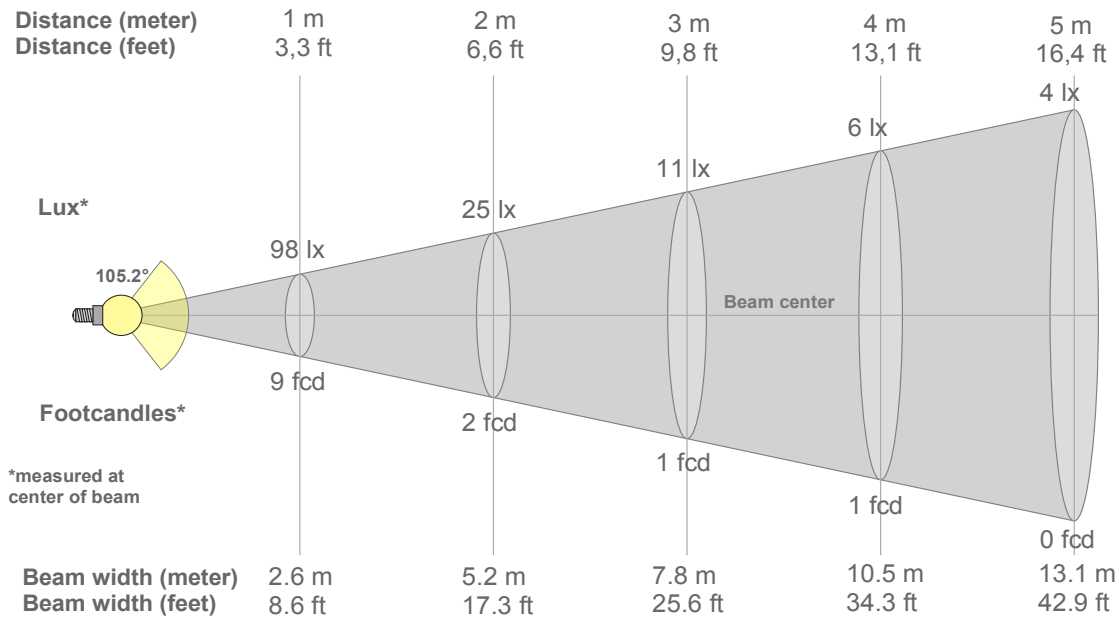

**Beam intensities from 1-20m**

1m	2m	3m	4m	5m	6m	7m	8m	9m	10m	11m	12m	13m	14m	15m	16m	17m	18m	19m	20m
3.3ft	6.6ft	9.8ft	13.1ft	16.4ft	19.7ft	23ft	26.2ft	29.5ft	32.8ft	36.1ft	39.4ft	42.7ft	45.9ft	49.2ft	52.5ft	55.8ft	59.1ft	62.3ft	65.6ft
98lx	25lx	11lx	6lx	4lx	3lx	2lx	2lx	1lx	1lx	1lx	1lx	1lx	1lx	0lx	0lx	0lx	0lx	0lx	0lx
9.1fcd	2.3fcd	1fcd	0.6fcd	0.4fcd	0.3fcd	0.2fcd	0.1fcd	0.1fcd	0.1fcd	0.1fcd	0.1fcd	0.1fcd	0fcd	0fcd	0fcd	0fcd	0fcd	0fcd	0fcd

**Intensities in 0° c-plane**

0°	5°	10°	15°	20°	25°	30°	35°	40°	45°	50°	55°	60°	65°	70°	75°	80°	85°	90°	95°
98.5	98.0	96.5	94.1	90.8	86.7	81.8	76.0	69.4	62.0	53.7	45.0	36.5	28.1	20.5	14.0	9.0	5.2	2.6	1.1
100%	99%	98%	96%	92%	88%	83%	77%	71%	63%	55%	46%	37%	29%	21%	14%	9%	5%	3%	1%

**Intensities in 90° c-plane**

0°	5°	10°	15°	20°	25°	30°	35°	40°	45°	50°	55°	60°	65°	70°	75°	80°	85°	90°	95°
98.5	98.0	96.5	94.1	90.8	86.7	81.8	76.0	69.4	62.0	53.7	45.0	36.5	28.1	20.5	14.0	9.0	5.2	2.6	1.1
100%	99%	98%	96%	92%	88%	83%	77%	71%	63%	55%	46%	37%	29%	21%	14%	9%	5%	3%	1%

**Intensities in 180° c-plane**

0°	5°	10°	15°	20°	25°	30°	35°	40°	45°	50°	55°	60°	65°	70°	75°	80°	85°	90°	95°
98.5	98.0	96.5	94.1	90.8	86.7	81.8	76.0	69.4	62.0	53.7	45.0	36.5	28.1	20.5	14.0	9.0	5.2	2.6	1.1
100%	99%	98%	96%	92%	88%	83%	77%	71%	63%	55%	46%	37%	29%	21%	14%	9%	5%	3%	1%

**Intensities in 270° c-plane**

0°	5°	10°	15°	20°	25°	30°	35°	40°	45°	50°	55°	60°	65°	70°	75°	80°	85°	90°	95°
98.5	98.0	96.5	94.1	90.8	86.7	81.8	76.0	69.4	62.0	53.7	45.0	36.5	28.1	20.5	14.0	9.0	5.2	2.6	1.1
100%	99%	98%	96%	92%	88%	83%	77%	71%	63%	55%	46%	37%	29%	21%	14%	9%	5%	3%	1%

Beam angle 50%	Field angle 10%	Cutoff angle 2,5%	Intensity ratio in 120° cone	Intensity ratio in 90° cone
105.2°	158.2°	180.6°	80.2%	56.0%

Note: specifications are representative of the diode type and not a particular tape light article.

4200K

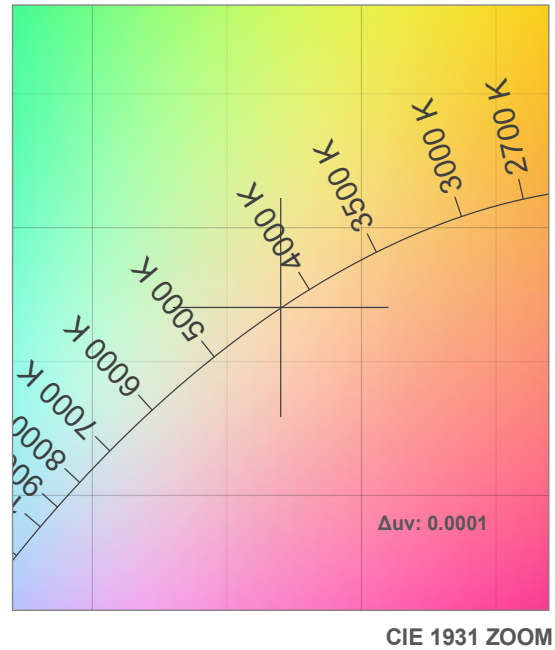
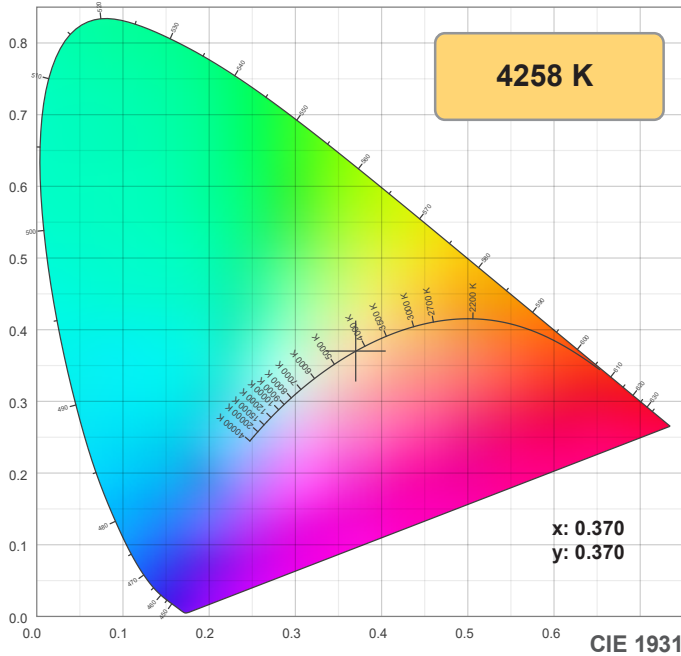

TM-30: 93.1

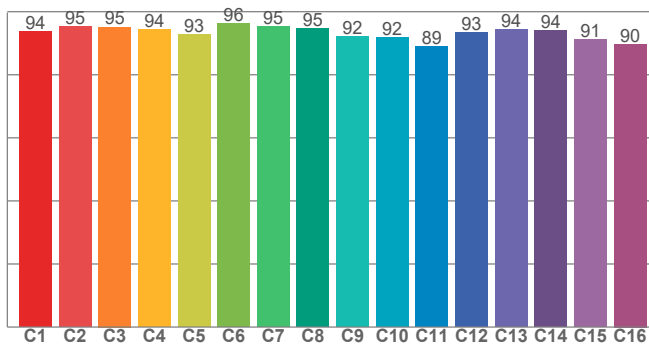

CRI: 95.5 (R1-R8)

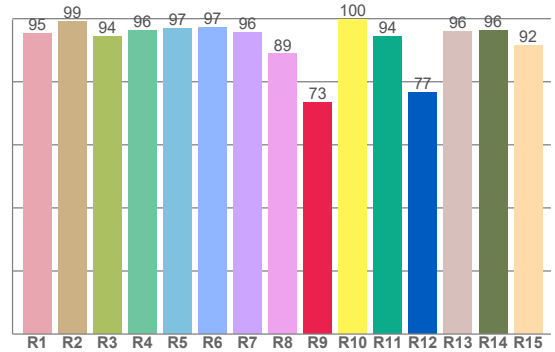

CRI R values, only R1-R8 are used to calculate final CRI value

R1	R2	R3	R4	R5	R6	R7	R8	R9	R10	R11	R12	R13	R14	R15
95.3	99.1	94.4	96.4	97.0	97.1	95.6	88.8	73.5	99.7	94.3	76.6	96.0	96.3	91.6

TM30 C values, 16 binned values out of total of 99 C values

C1	C2	C3	C4	C5	C6	C7	C8	C9	C10	C11	C12	C13	C14	C15	C16
93.8	95.4	95.1	94.3	92.7	96.3	95.4	94.6	92.2	91.8	88.8	93.4	94.5	94.2	91.3	89.7

CQS Q values

Q1	Q2	Q3	Q4	Q5	Q6	Q7	Q8	Q9	Q10	Q11	Q12	Q13	Q14	Q15
92.4	99.9	92.1	93.2	97.0	99.5	98.8	98.4	97.0	99.2	98.3	96.1	95.6	98.0	95.1

CQS: 95.9

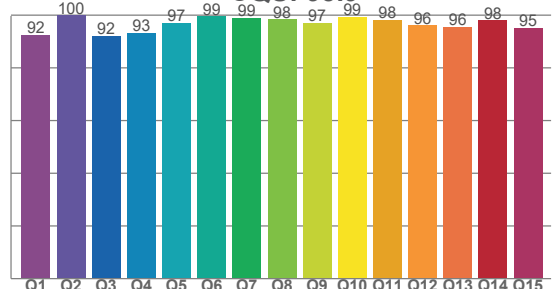

Color parameters

Color temperature	Color rendering index	Red component	Color fidelity	Color gamut	Color quality scale	Color coordinate cie 1931	Color coordinate cie 1931	Color coordinate	Color coordinate	Color deviation from black body
CCT	CRI	CRI R9	TM30 Rf	TM30 Rg	CQS	x	y	u	v	Δuv
4258 K	95.5	73.5	93.1	101.8	95.9	0.370	0.370	0.221	0.331	0.0001

Note: specifications are representative of the diode type and not a particular tape light article.

4200K

**Rf 93.1**  
Fidelity index Rf

**Rg 101.8**  
Gamut index Rg

Hue Bin	R <sub>f</sub>	Shifts (%)	
		Chroma	Hue
1	94	3%	0%
2	95	2%	-2%
3	95	1%	-2%
4	94	-3%	-2%
5	93	-5%	-1%
6	96	-1%	1%
7	95	-1%	2%
8	95	0%	3%
9	92	0%	6%
10	92	1%	5%
11	89	3%	7%
12	93	3%	3%
13	94	3%	2%
14	94	1%	2%
15	91	4%	0%
16	90	5%	-3%

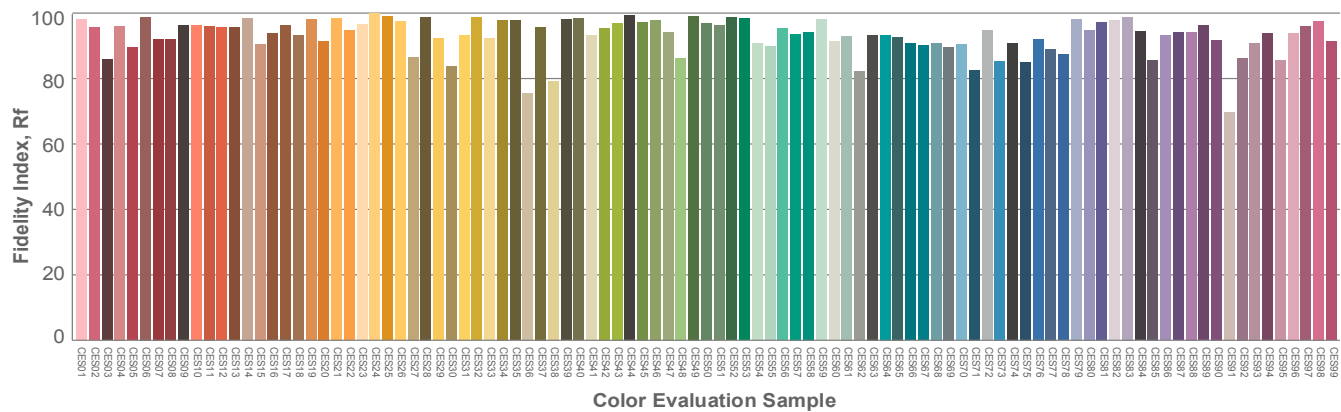
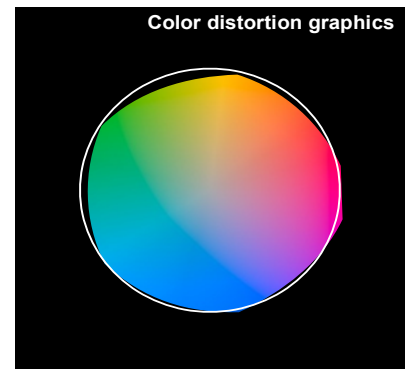
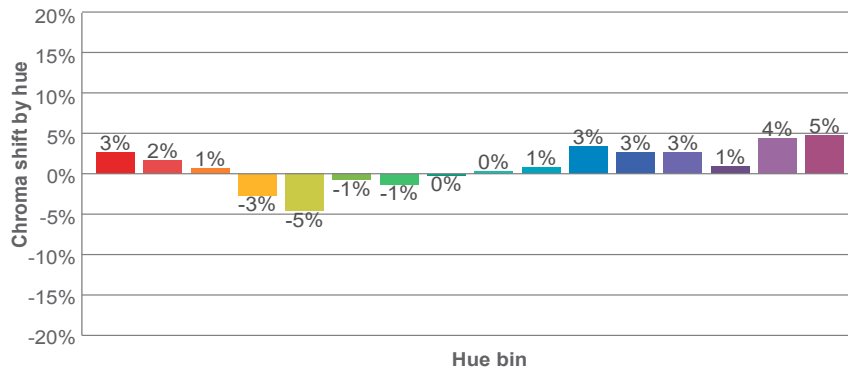
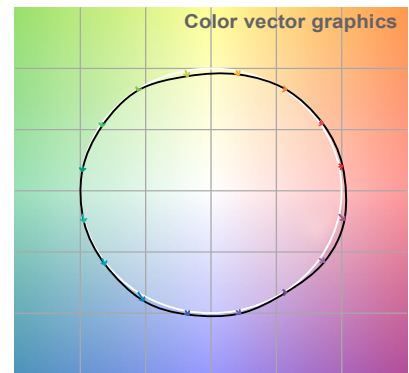
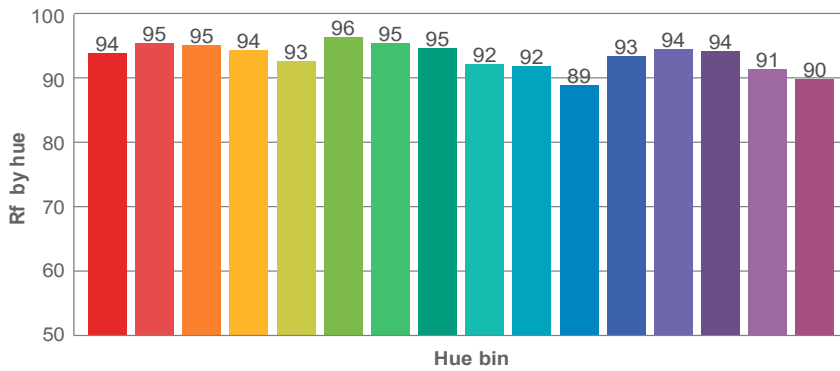
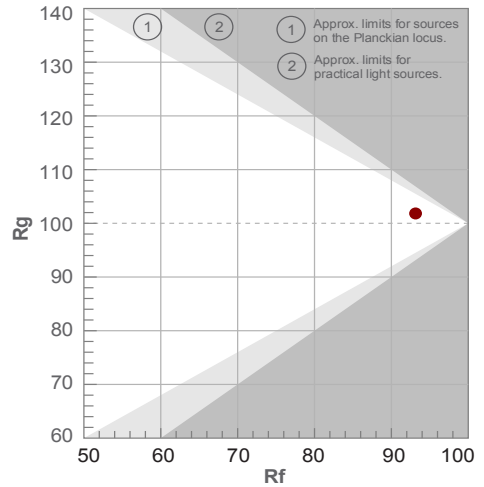



Note: specifications are representative of the diode type and not a particular tape light article.

4200K

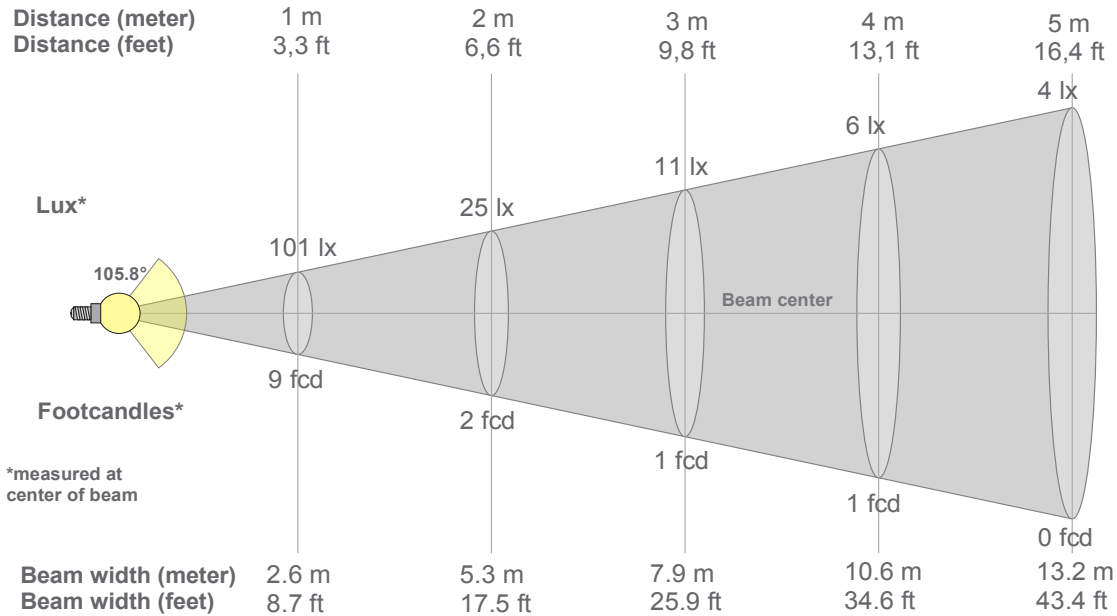

**Beam intensities from 1-20m**

1m	2m	3m	4m	5m	6m	7m	8m	9m	10m	11m	12m	13m	14m	15m	16m	17m	18m	19m	20m
3.3ft	6.6ft	9.8ft	13.1ft	16.4ft	19.7ft	23ft	26.2ft	29.5ft	32.8ft	36.1ft	39.4ft	42.7ft	45.9ft	49.2ft	52.5ft	55.8ft	59.1ft	62.3ft	65.6ft
101lx	25lx	11lx	6lx	4lx	3lx	2lx	2lx	1lx	1lx	1lx	1lx	1lx	1lx	0lx	0lx	0lx	0lx	0lx	0lx
9.4fcd	2.3fcd	1fcd	0.6fcd	0.4fcd	0.3fcd	0.2fcd	0.1fcd	0.1fcd	0.1fcd	0.1fcd	0.1fcd	0.1fcd	0fcd	0fcd	0fcd	0fcd	0fcd	0fcd	0fcd

**Intensities in 0° c-plane**

0°	5°	10°	15°	20°	25°	30°	35°	40°	45°	50°	55°	60°	65°	70°	75°	80°	85°	90°	95°
101	100	99	97	93	89	84	78	72	64	56	47	38	29	21	15	10	6	3	1
100%	100%	98%	96%	93%	88%	83%	78%	71%	63%	55%	46%	38%	29%	21%	15%	9%	6%	3%	1%

**Intensities in 90° c-plane**

0°	5°	10°	15°	20°	25°	30°	35°	40°	45°	50°	55°	60°	65°	70°	75°	80°	85°	90°	95°
101	100	99	97	93	89	84	78	72	64	56	47	38	29	21	15	10	6	3	1
100%	100%	98%	96%	93%	88%	83%	78%	71%	63%	55%	46%	38%	29%	21%	15%	9%	6%	3%	1%

**Intensities in 180° c-plane**

0°	5°	10°	15°	20°	25°	30°	35°	40°	45°	50°	55°	60°	65°	70°	75°	80°	85°	90°	95°
101	100	99	97	93	89	84	78	72	64	56	47	38	29	21	15	10	6	3	1
100%	100%	98%	96%	93%	88%	83%	78%	71%	63%	55%	46%	38%	29%	21%	15%	9%	6%	3%	1%

**Intensities in 270° c-plane**

0°	5°	10°	15°	20°	25°	30°	35°	40°	45°	50°	55°	60°	65°	70°	75°	80°	85°	90°	95°
101	100	99	97	93	89	84	78	72	64	56	47	38	29	21	15	10	6	3	1
100%	100%	98%	96%	93%	88%	83%	78%	71%	63%	55%	46%	38%	29%	21%	15%	9%	6%	3%	1%

Beam angle 50%	Field angle 10%	Cutoff angle 2,5%	Intensity ratio in 120° cone	Intensity ratio in 90° cone
105.8°	158.9°	181.9°	79.9%	55.8%